

ANSI Class 150 P-T Chart

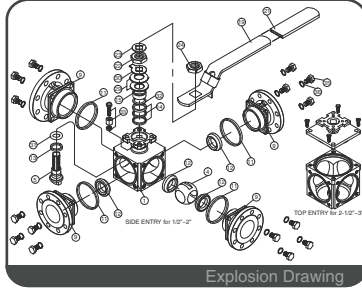

Explosion Drawing

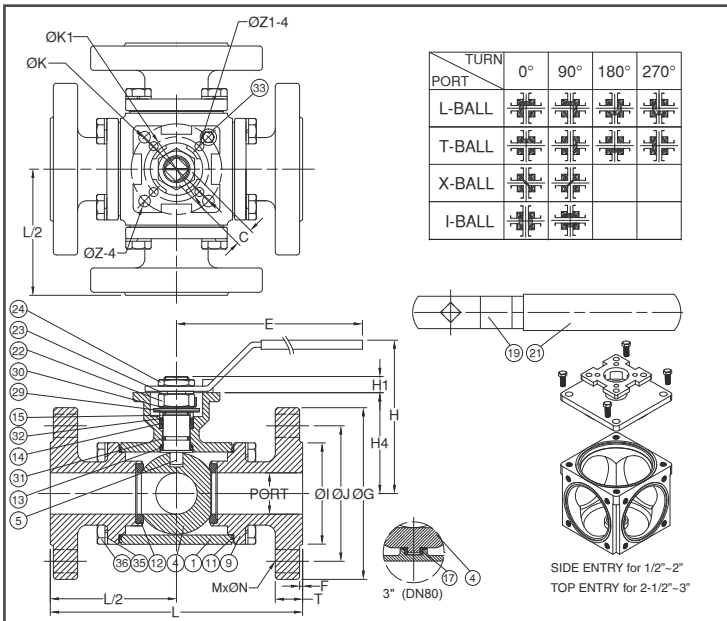

TURN PORT	0°	90°	180°	270°
L-BALL				
T-BALL				
X-BALL				
I-BALL				

FEATURES

- Investment Cast Body Construction
- 4 Way Flanged Ball Valve
- 4 Pieces of Seats Design
- ISO 5211 Direct Mounting Flange for 1/2" ~ 3"
ISO 5211 Mounting Flange for 4" ~ 6"
- Blow-Out-Proof Stem Design
- Available for T/L/X/I Port
- Locking Device **OPTION**
- NACE MR0175 is available upon request
- Super Alloy materials for highly corrosive medium are available upon request

AUTOMATION AVAILABLE

SPECIFICATIONS

- Size Range 1/2" ~ 6" (DN15 ~ DN150)
- End Connection Flanged End, RF
- Working Pressure
CF8M - 275 PSI (CWP)
WCB - 285 PSI (CWP)
- Steam Pressure 150 PSIG. Saturated Steam for RTFE.
- Temperature Range -4 to 356 °F (-20 to 180 °C) for RTFE.

STANDARDS

- Design ASME/ANSI B16.34
- Mounting Flange ISO 5211
- Face to Face MFG Standard
- Flange Dimension ASME/ANSI B16.5 Class 150 RF
- Material ASTM
- Pressure Testing API 598

CERTIFICATE

- Quality Assurance ISO 9001
- Material Certificate EN 10204-3.1 MTR
- CE Approval PED 97/23/EC Module H
- Canadian Certificate CRN

MATERIAL LIST

NO.	PART NAME	MATERIAL (more options available)
1	BODY	ASTM A351 Gr.CF8M ASTM A216 Gr.WCB
4	BALL	ASTM A351 Gr.CF8M
5	STEM	ASTM A276 Gr.316 ASTM A351 Gr.CF8M
9	END CAP	ASTM A216 Gr.WCB
11	BODY SEAL	PTFE.
12	SEAT	RTFE. (15%G.F.)
13	THRUST WASHER	RTFE. (15%G.F.)
14	STEM PACKING	RTFE. (15%G.F.)
15	GLAND BUSH	SS304
17	BUSHING	PTFE.
19	HANDLE	SS304
21	HANDLE COVER	PLASTIC
22	STEM NUT	SS304
23	HANDLE WASHER	SS304
24	HANDLE NUT	SS304
29	BELLEVILLE WASHER	SS
30	TAB WASHER	SS304
31	O-RING	VITON®
32	PACKING FOLLOWER	PTFE. +25%G.F.
33	STOP PIN	SS304
35	BODY BOLT	SS304
36	BOLT WASHER	SS304

DIMENSION

SIZE	PORT	L	E	H	H1	H4	ØG	ØJ	ØI	ØK	ØK1	Z	Z1	C	T	F	MxØN
DN15	1/2"	16.0	147.4	186.5	89.0	9.0	47.8	89.0	60.5	35.0	42/F04	6	9	11.2	1.6	4xØ16	
DN20	3/4"	20.0	155.8	218.0	98.0	11.0	58.2	98.6	70.0	43.0	50/F05	7	11	12.7	1.6	4xØ16	
DN25	1"	25.0	168.8	218.0	102.0	11.5	64.0	108.0	79.2	51.0	50/F05	7	11	14.3	1.6	4xØ16	
DN32	1-1/4"	32.0	197.9	235.0	118.5	15.2	79.0	117.5	88.9	63.5	70/F07	9	7	14	15.9	1.6	4xØ16
DN40	1-1/2"	38.0	221.4	235.0	127.0	14.3	88.5	127.0	98.6	73.2	70/F07	9	7	14	17.5	1.6	4xØ16
DN50	2"	50.0	244.6	252.0	139.0	17.8	105.8	152.5	120.7	92.0	102/F10	11	9	17	19.1	1.6	4xØ19
DN65	2-1/2"	65.0	270.0	302.0	165.7	17.5	117.3	177.8	139.7	104.7	102/F10	11	9	17	23.3	1.6	4xØ19
DN80	3"	80.0	292.2	302.0	170.0	17.5	128.0	190.5	152.4	127.0	102/F10	11	9	17	23.9	1.6	4xØ19

DIMENSION

SIZE	PORT	L	E	H	H1	H4	ØG	ØJ	ØI	ØK	ØK1	Z	Z1	C	T	F	MxØN
DN15	1/2"	0.62	5.80	7.34	3.50	0.35	1.88	3.50	2.38	1.37	1.65/F04	0.23	0.35	0.44	0.06	4xØ0.62	
DN20	3/4"	0.78	6.13	8.58	3.85	0.43	2.29	3.88	2.75	1.69	1.96/F05	0.27	0.43	0.50	0.06	4xØ0.62	
DN25	1"	0.98	6.64	8.58	4.01	0.45	2.51	4.25	3.11	2.00	1.96/F05	0.27	0.43	0.56	0.06	4xØ0.62	
DN32	1-1/4"	1.25	7.79	9.25	4.66	0.59	3.11	4.62	3.50	2.50	2.75/F07	0.35	0.27	0.55	0.62	0.06	4xØ0.62
DN40	1-1/2"	1.49	8.71	9.25	5.00	0.56	3.48	5.00	3.88	2.88	2.75/F07	0.35	0.27	0.55	0.68	0.06	4xØ0.62
DN50	2"	1.96	9.62	9.92	5.47	0.70	4.16	6.00	4.75	3.62	4.01/F10	0.43	0.35	0.66	0.75	0.06	4xØ0.74
DN65	2-1/2"	2.55	10.62	11.88	6.52	0.68	4.61	7.00	5.50	4.12	4.01/F10	0.43	0.35	0.66	0.91	0.06	4xØ0.74
DN80	3"	3.14	11.50	11.88	6.69	0.68	5.03	7.50	6.00	5.00	4.01/F10	0.43	0.35	0.66	0.94	0.06	4xØ0.74

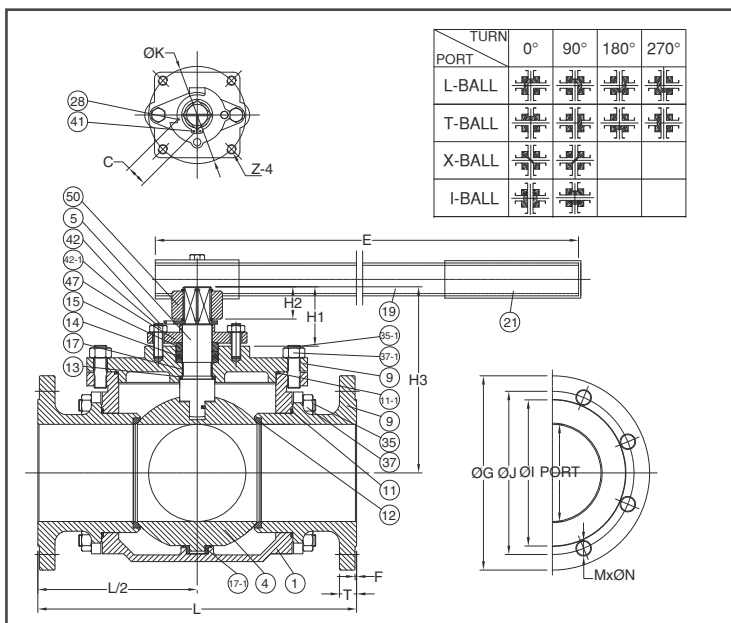
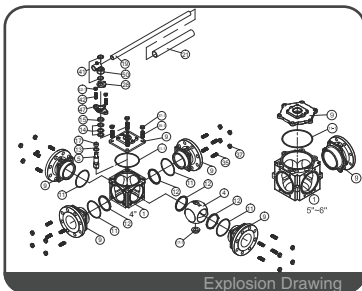
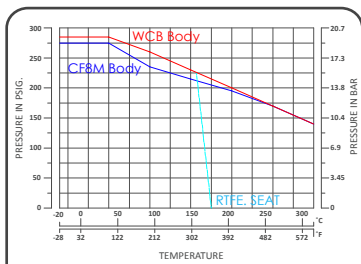

FEATURES

- Investment Cast Body Construction
- 4 Way Flanged Ball Valve
- 4 Pieces of Seats Design
- ISO 5211 Direct Mounting Flange for 1/2" ~ 3"
ISO 5211 Mounting Flange for 4" ~ 6"
- Blow-Out-Proof Stem Design
- Available for T/L/X/I Port
- Locking Device **OPTION**
- NACE MR0175 is available upon request
- Super Alloy materials for highly corrosive medium are available upon request

AUTOMATION AVAILABLE

SPECIFICATIONS

- Size Range 1/2" ~ 6" (DN15 ~ DN150)
- End Connection Flanged End, RF
- Working Pressure
CF8M - 275 PSI (CWP)
WCB - 285 PSI (CWP)
- Steam Pressure 150 PSIG. Saturated Steam for RTFE.
- Temperature Range -4 to 356 °F (-20 to 180 °C) for RTFE.

STANDARDS

- Design ASME/ANSI B16.34
- Mounting Flange ISO 5211
- Face to Face MFG Standard
- Flange Dimension ASME/ANSI B16.5 Class 150 RF
- Material ASTM
- Pressure Testing API 598

CERTIFICATE

- Quality Assurance ISO 9001
- Material Certificate EN 10204-3.1 MTR
- CE Approval PED 97/23/EC Module H
- Canadian Certificate CRN

MATERIAL LIST

NO.	PART NAME	MATERIAL (more options available)
1	BODY	ASTM A351 Gr.CF8M
		ASTM A216 Gr.WCB
4	BALL	ASTM A351 Gr.CF8M
5	STEM	ASTM A276 Gr.316
9	END/TOP CAP	ASTM A351 Gr.CF8M
		ASTM A216 Gr.WCB
11	BODY SEAL	PTFE.
11-1	TOP SEAL	PTFE.
12	SEAT	RTFE.(15%G.F.)
13	THRUST WASHER	RTFE.(15%G.F.)
14	STEM PACKING	RTFE.(15%G.F.)
15	GLAND BUSH	SS304
17	STEM BUSH	SS304
17-1	BUSHING	PTFE.
19	HANDLE	IRON
21	HANDLE COVER	PLASTIC
28	STOP PLATE	SS304
35	BODY BOLT	SS304
35-1	BODY BOLT	SS304
37	BOLT NUT	SS304
37-1	BOLT NUT	SS304
41	SNAP RING	SS304
42	GLAND BOLT	SS304
42-1	GLAND NUT	SS304
47	GLAND FLANGE	ASTM A351 Gr.CF8
50	ADAPTER	ASTM A351 Gr.CF8

DIMENSION

unit : mm

SIZE	PORT	L	E	H1	H2	H3	ØG	ØJ	ØI	ØK	Z	C	T	F	MxØN	
DN100	4"	100	368.0	600	70.0	33.0	193.0	228.6	190.5	157.2	125/F12	M12x1.75P	27	23.9	1.6	8xØ19
DN125	5"	125	420.0	600	70.0	33.0	233.0	254.0	216.0	186.0	125/F12	M12x1.75P	27	24.0	1.6	8xØ22.3
DN150	6"	150	479.4	800	77.5	43.5	266.0	279.4	241.3	216.0	140/F14	M16x2.0P	36	25.4	1.6	8xØ22.3

DIMENSION

unit : inch

SIZE	PORT	L	E	H1	H2	H3	ØG	ØJ	ØI	ØK	Z	C	T	F	MxØN	
DN100	4"	3.93	14.48	23.62	2.75	1.29	7.59	9.00	7.50	6.18	4.92/F12	M12x1.75P	1.06	0.94	0.06	8xØ0.74
DN125	5"	4.92	16.53	23.62	2.75	1.29	9.17	10.00	8.50	7.32	4.92/F12	M12x1.75P	1.06	0.94	0.06	8xØ0.87
DN150	6"	5.90	18.87	31.49	3.05	1.71	10.47	11.00	9.50	8.50	5.51/F14	M16x2.0P	1.41	1.00	0.06	8xØ0.87