



FEATURES

- Investment Cast Body Construction
- Horizontal Style
- Swing Type
- Solid Disc
- Screwed Bonnet
- For General Chemical and Industrial application

SPECIFICATIONS

- Size Range DN8 ~ DN80 (1/4" ~ 3")
- End Connection Threaded Ends
- Working Pressure 16 Bar at RT
- Operating Pressure 0.15 kgf/cm²
- Temperature Range -4 to 320 °F (-20 to 160 °C) for PTFE.

STANDARDS

- Design EN 12516-1/3
- Threaded End NPT/ BS 21 (BSP) / BSPT / ISO 228-1 / DIN 2999 / ISO 7-1Rp
- Face to Face MFG Standard
- Material EN1503-1
- Pressure Testing EN 12266

CERTIFICATE

- Quality Assurance ISO 9001
- Material Certificate EN 10204-3.1 MTR
- CE Approval PED 97/23/EC Module H

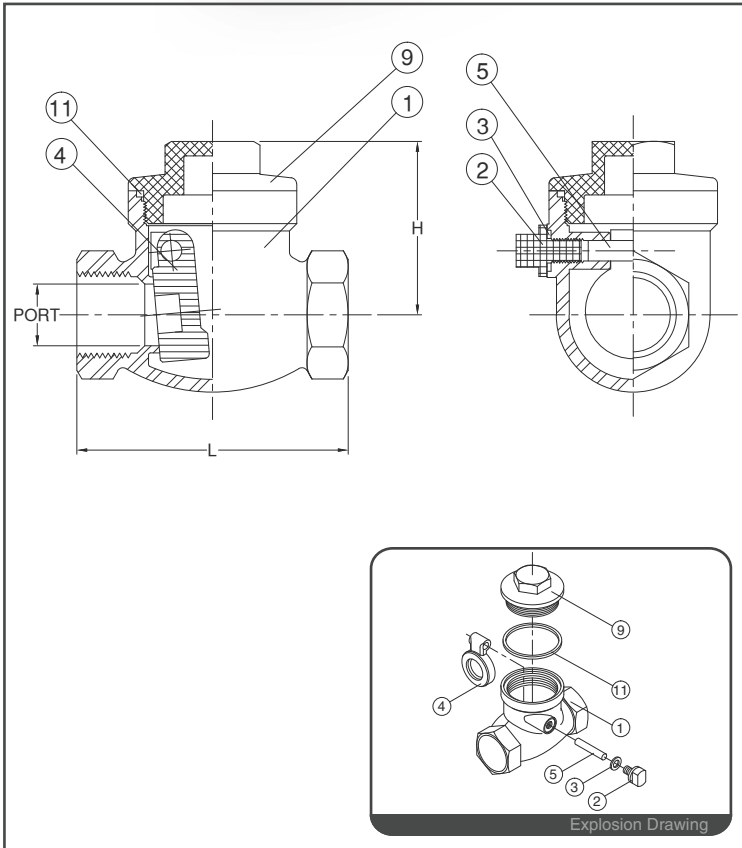

MATERIAL LIST

NO.	PART NAME	MATERIAL (more options available)
1	BODY	EN1503-1 1.4408
2	PLUG	ASTM A276 Gr.316
3	PLUG SEAL	TEFLON
4	DISC	EN1503-1 1.4408
5	HANGER PIN	ASTM A276 Gr.316
9	BONNET	EN1503-1 1.4408
11	GASKET	TEFLON

DIMENSION

unit : mm

SIZE		PORT	L	H
DN8	1/4"	11.0	65.0	42.0
DN10	3/8"	15.0	65.0	42.0
DN15	1/2"	15.0	65.0	42.0
DN20	3/4"	20.0	80.0	51.0
DN25	1"	25.0	90.0	60.0

DIMENSION

unit : inch

SIZE		PORT	L	H
DN8	1/4"	0.43	2.56	1.65
DN10	3/8"	0.59	2.56	1.65
DN15	1/2"	0.59	2.56	1.65
DN20	3/4"	0.79	3.15	2.01
DN25	1"	0.98	3.54	2.36



FEATURES

- Investment Cast Body Construction
- Horizontal Style
- Swing Type
- Solid Disc
- Screwed Bonnet
- For General Chemical and Industrial application

SPECIFICATIONS

- Size Range DN8 ~ DN80 (1/4" ~ 3")
- End Connection Threaded Ends
- Working Pressure 16 Bar at RT
- Operating Pressure 0.15 kgf/cm²
- Temperature Range -4 to 320 °F (-20 to 160 °C) for PTFE.

STANDARDS

- Design EN 12516-1/3
- Threaded End NPT/ BS 21 (BSP) / BSPT / ISO 228-1 / DIN 2999 / ISO 7-1Rp
- Face to Face MFG Standard
- Material EN1503-1
- Pressure Testing EN 12266

CERTIFICATE

- Quality Assurance ISO 9001
- Material Certificate EN 10204-3.1 MTR
- CE Approval PED 97/23/EC Module H

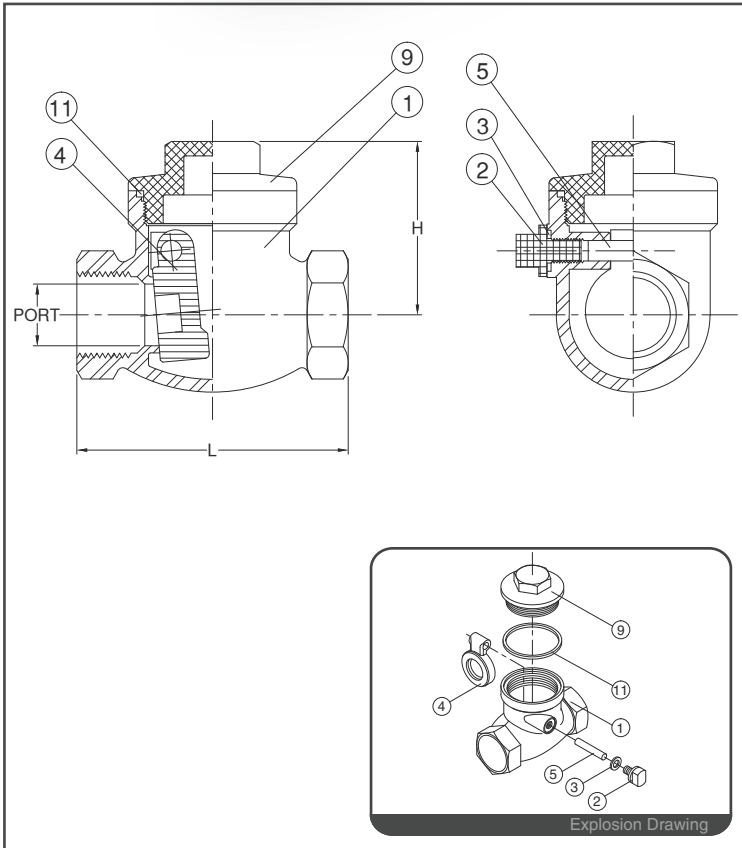

MATERIAL LIST

NO.	PART NAME	MATERIAL (more options available)
1	BODY	EN1503-1 1.4408
2	PLUG	ASTM A276 Gr.316
3	PLUG SEAL	TEFLON
4	DISC	EN1503-1 1.4408
5	HANGER PIN	ASTM A276 Gr.316
9	BONNET	EN1503-1 1.4408
11	GASKET	TEFLON

DIMENSION

unit : mm

SIZE		PORT	L	H
DN32	1-1/4"	32.0	105.0	67.0
DN40	1-1/2"	40.0	120.0	75.0
DN50	2"	50.0	140.0	81.0
DN65	2-1/2"	65.0	180.0	93.0
DN80	3"	80.0	200.0	104.0

DIMENSION

unit : inch

SIZE		PORT	L	H
DN32	1-1/4"	1.26	4.13	2.64
DN40	1-1/2"	1.57	4.72	2.95
DN50	2"	1.97	5.51	3.19
DN65	2-1/2"	2.56	7.09	3.66
DN80	3"	3.15	7.87	4.09